



# OAG Manual

Version 2.0

Aug 2019

All materials related to this publication are subject to change without notice and its copyright totally belongs to Suzhou ZWO CO.,LTD.

# 1. Instruction

Congratulations and thank you for buying our OAG! This manual will give you a brief introduction to our OAG. Please take the time to read it thoroughly and if you have any other questions, feel free to contact us. [info@zwoptical.com](mailto:info@zwoptical.com)

# 2. Description

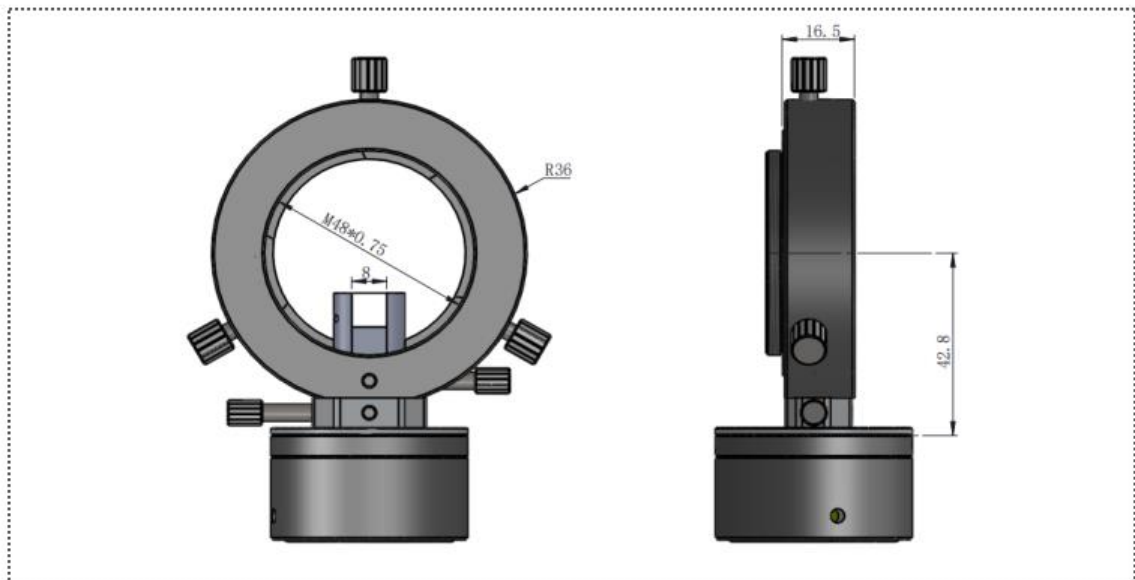

The new product OAG

1. Lightweight, beautiful outlook, 16.5mm thickness
2. Large prism:8\*8mm
3. Connect the main imaging camera and the guide camera. No guide scope required!
4. Fully compatible with all ZWO ASI cameras, and equipping M42 adapter and M48 adapter
5. No looseness with the hexagon socket head cap screw

### 3. What's in the box?



1. OAG body(with 1.25" holder and 5mm extender and M42 adapter)
2. M48 adapter for main imaging camera
3. M48-M42 adapter for telescope
4. Hexagon wrench

## 4. How to connect OAG with your camera and telescope

Here are the steps to show you how to connect OAG with ASI071MC-Pro and your scope.





Note: please make sure the prism won't block the imaging area

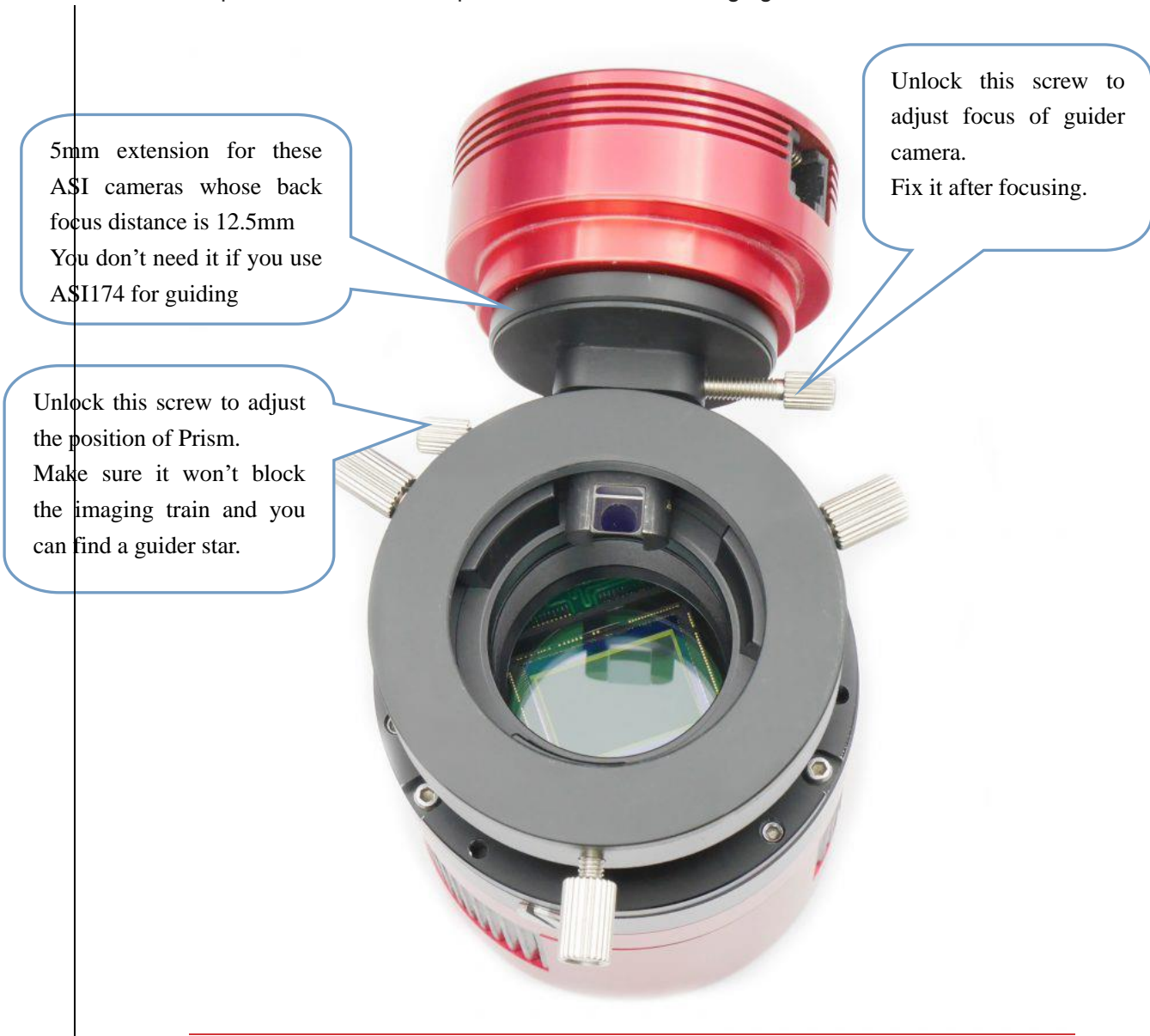

You'd better do it at day time to make sure imaging camera and guiding camera can reach focus together.



Here is an example of the whole setup including an OAG and guider camera.



## 5. Other recommendations

Match it with OAG for more convenient guiding experience; It can also perfectly fit in with all AS

I mini series cameras and other situations when focusing required.

ADD: <https://astronomy-imaging-camera.com/product/zwo-1-25%e2%80%b3-helical-focuser>



## 6. Servicing

Repairs and servicing are available by emailing [info@zwoptical.com](mailto:info@zwoptical.com)

For customers who bought the product from your local dealer, dealer is responsible for the customer service.

## 7. Warranty

We provide 2-year warranty for our products. We offer repair service or replacement for free if the



product doesn't work within warranty period.

After the warranty period, we continue to provide repair support and service on a charged basis.

This warranty does not apply to damage that occurred as a result of abuse or misuse, or caused by a fall or any other transportation failures after purchase.

Customer must pay for shipping when shipping the camera back for repair or replacement.