



ASI174 Manual

Revision 1.5

Feb, 2022

All materials related to this publication are subject to change without notice and its copyright totally belongs to Suzhou ZWO CO.,LTD.



ASI174 Manual	1
1. Instruction	3
2. Camera Models and Sensor Type	4
3. What's in the box?.....	5
4. Camera technical specifications	6
5. QE Graph & Read Noise	7
6. Getting to know your camera	9
6.1 External View.....	9
6.2 Power consumption:	9
6.3 Protect Window.....	9
6.4 Analog to Digital Converter (ADC)	10
6.5 Binning.....	10
7. How to use your camera	11
8. Clean the camera and redry desiccant	13
9. Mechanical drawing.....	14
10. Servicing	15
11. Warranty.....	15

1. Instruction

Congratulations and thank you for buying one of our ASI Cameras! This manual will give you a brief introduction to your ASI camera. Please read it thoroughly. If you have any other questions, please feel free to contact us. info@zwoptical.com

ASI174 Cameras are designed for astronomical photography.
Its excellent performance and multifunctional usage will impress you a lot!

For software installation instructions and other technical information please refer to “Support” on our official website.

<https://astronomy-imaging-camera.com/>

2. Camera Models and Sensor Type

There are 4 types of ASI174 models:

Models	Mono or Color	Interface	Sensor
ASI174MM	Mono	USB2.0	IMX174LLJ
ASI174MC	Color	USB2.0	IMX174LQJ
ASI174MM-C	Mono	USB3.0	IMX174LLJ
ASI174MC-C	Color	USB3.0	IMX174LQJ

Why do I choose ASI174?

Our ASI174 comes with a large sensor, large pixel size, high frame rate and comparatively high resolution. Most importantly, with SONY IMX174 CMOS sensor, this image sensor makes SONY Pregius Global Shutter CMOS technology available for amateurs who wants to focus on high quality Lunar , Solar and deep sky imaging.

Monochrome VS Color

Monochrome camera sensors are capable of higher details and sensitivity than color sensors, but you need additional accessories such as filter wheel and filters. The post-processing is more complicated too. So color camera is often recommended for beginner of astrophotographer.

TEC cooling will help to reduce dark current noise for long exposures. For short exposures, such as under one second, the dark current noise is very low. However, cooling is recommended for DSO imaging when long exposures are required.

3. What's in the box?

ASI174MM and ASI174MC



ASI174MM-COOL or ASI174MC-COOL



4. Camera technical specifications

Sensor	IMX174LLJ / IMX174LQJ
Resolution	2.3Mega Pixels 1936×1216
Pixel Size	5.86μm
Max FPS at full resolution	164FPS(10bitADC)
Shutter	Global shutter
Exposure Range	32μs-1000s
Read Noise	3.5e @ 30db gain
QE peak	78%
ADC	12 bit/10 bit
Interface	USB3.0
Adapters	2" / 1.25" / M42X0.75
Back focus distance	Uncooled 6.5mm/Cooled 6.5mm
Dimensions	Uncooled 62mm/Cooled 78mm
Weight	Uncooled 140g/Cooled 410g
Cooling (cooled cameras) :	Regulated Two Stage TEC
Delta T	35°C-40°C below ambient
Cooling Power consumption	12V at 2A Max
Supported OS	Windows, Linux & Mac OSX
Working Temperature	-5°C—45°C
Storage Temperature	-20°C—60°C
Working Relative Humidity	20%—80%
Storage Relative Humidity	20%—95%

5. QE Graph & Read Noise

QE and Read noise are the most important parts to measure the performance of a camera.

Higher QE and Lower read noise are needed to improve the SNR of an image.

Relative QE : the peak value of QE is around 78%

ASI174 Mono Sensor

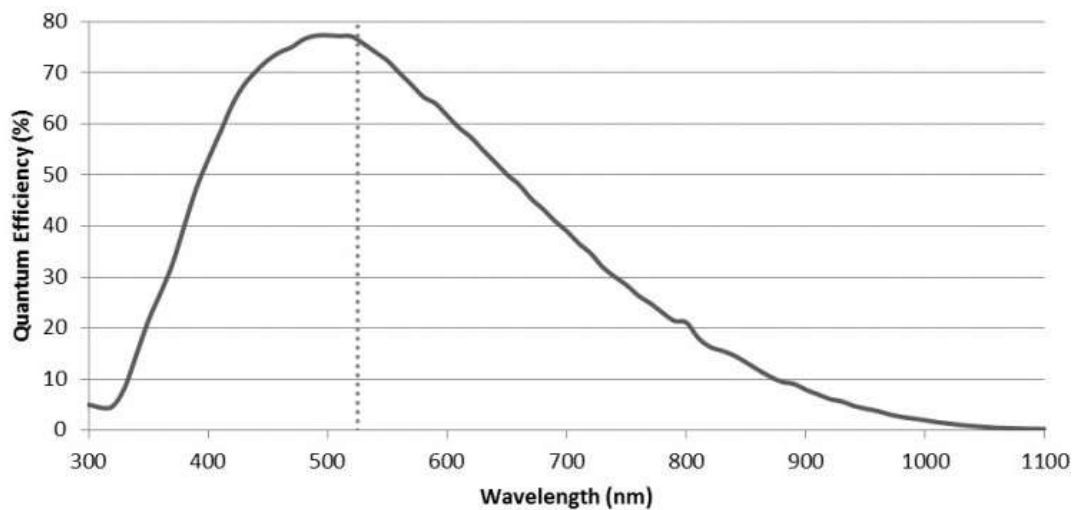

Read Noise includes pixel diode noise, circuit noise and ADC quantization error noise, and the lower the better.

The Read Noise of the ASI174 cameras is extremely lower when compared with traditional CCD cameras. It is even lower when the camera is set at a higher gain.

Depending on your target, you can set the Gain lower for higher Dynamic Range (longer exposure) or set the Gain higher for lower noise (such as short exposure or lucky imaging).

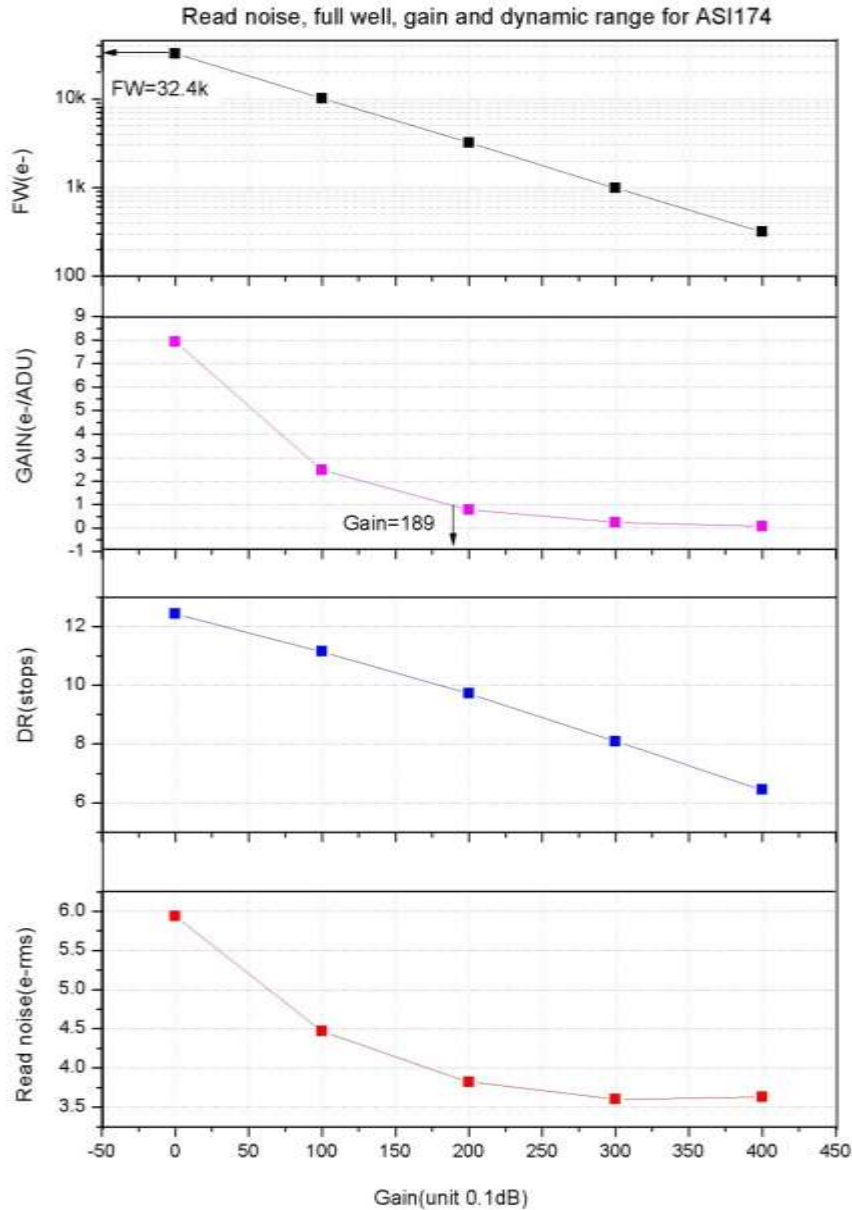

6. Getting to know your camera

6.1 External View

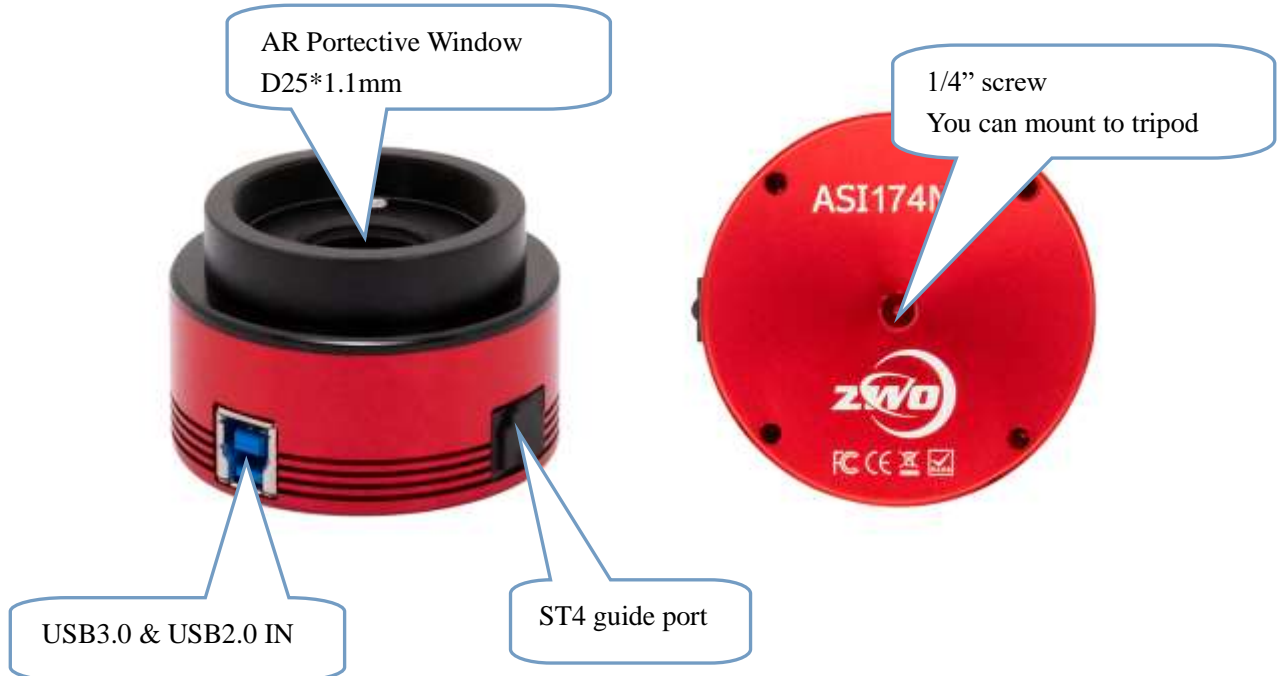

6.2 Power consumption:

ASI174 cameras are designed to have very low power consumption which is around 300ma@5V. You only need the USB cable to power up the camera.

6.3 Protect Window

There is an AR protect window in the ZWO ASI174MM. Diameter is 25mm, thickness is 1.1mm.

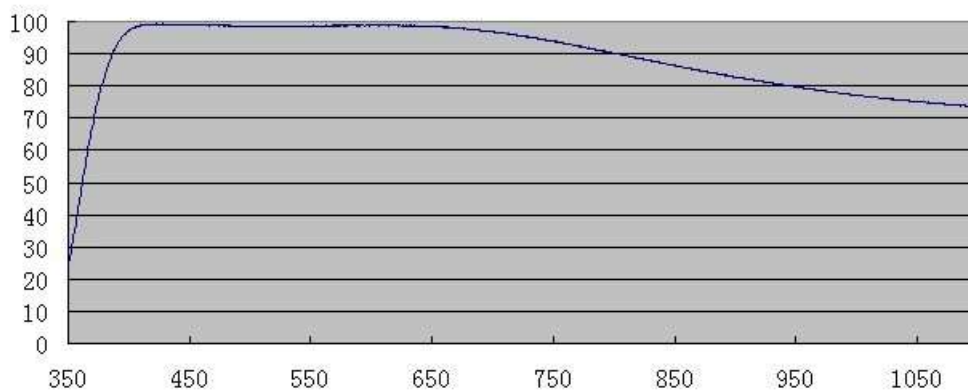

6.4 Analog to Digital Converter (ADC)

The ASI174 camera records in 12bit ADC and 10bit ADC. You can image at a faster fps rate if you choose to use 10bit ADC (high speed mode). This camera also supports ROI (region of interest) shooting, and this smaller ROI has faster fps.

*All the data was tested in RAW 8.

Resolution	12bit ADC	10bit ADC
1936x1216	128fps	164fps
640x480	309fps	397fps
320x240	577fps	740fps

6.5 Binning

The ASI174 camera supports software bin2 mode. You should use 10bit ADC. We recommend customer to use software binning if you don't care speed.

7. How to use your camera

There are many adapters available for this camera for connecting to your scope or lens. Some are included with the camera and others you can order from our site:

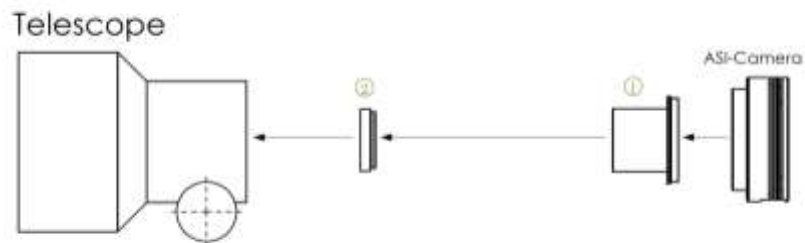

1. 1.25" T-Mount
2. 1.25" filter(optional)



Cooled Cameras
External Device Connecting Drawing



8. Clean the camera and redry desiccant

The camera comes with an AR protect window, which can protect the sensor from dust and humidity. Should you need to clean the sensor, it's better to do so during the daytime. To see the dust, you just need to setup your telescope and point it to a bright place. A Barlow is required to see these dusts clear. Then attach the camera and adjust the exposure to make sure not over exposed. You can see an image like below if it's dirty.

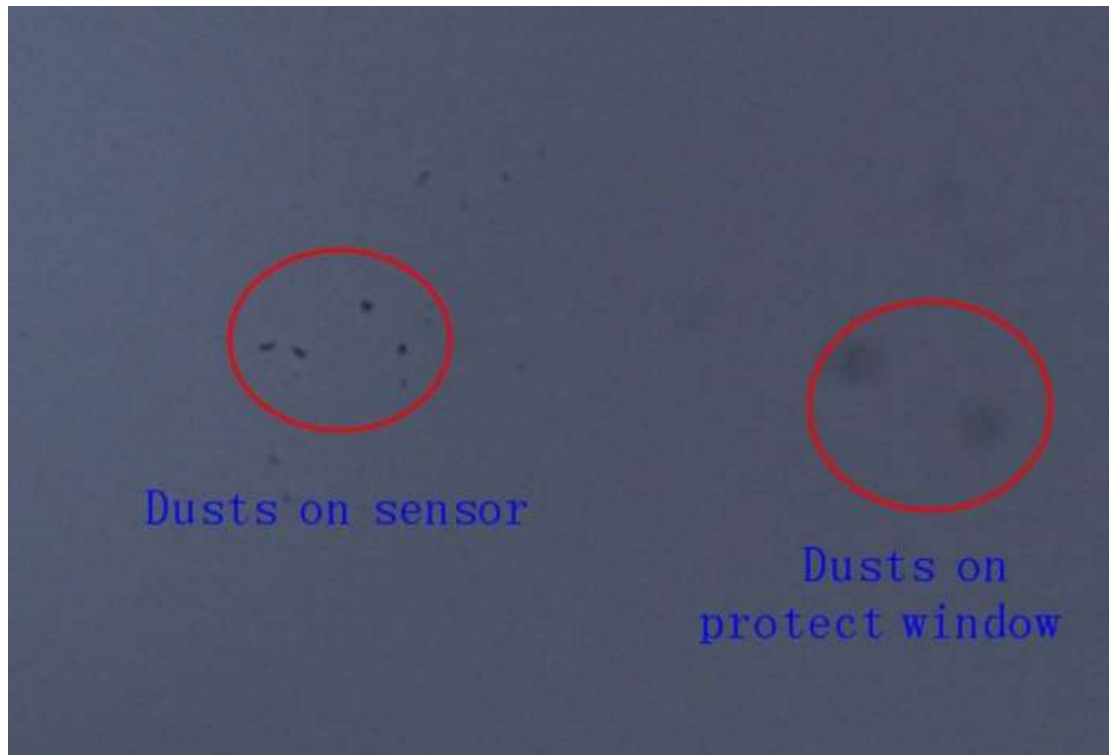

The big dim spot on the image (at right) are the shadows of dust on the protect window.

The very small but very dark spot in the image (at left) are the shadows of the dusts on the sensor.

The suggested way to clean them is try to blow them away with a manual air pump. To clean the dust on the sensor you will need to open the camera chamber.

We have a very detailed instruction on our website:

https://astronomy-imaging-camera.com/manuals/How_to_clean_ASI_camera_and_redry_the_desiccant.pdf

9. Mechanical drawing

ASI174MM

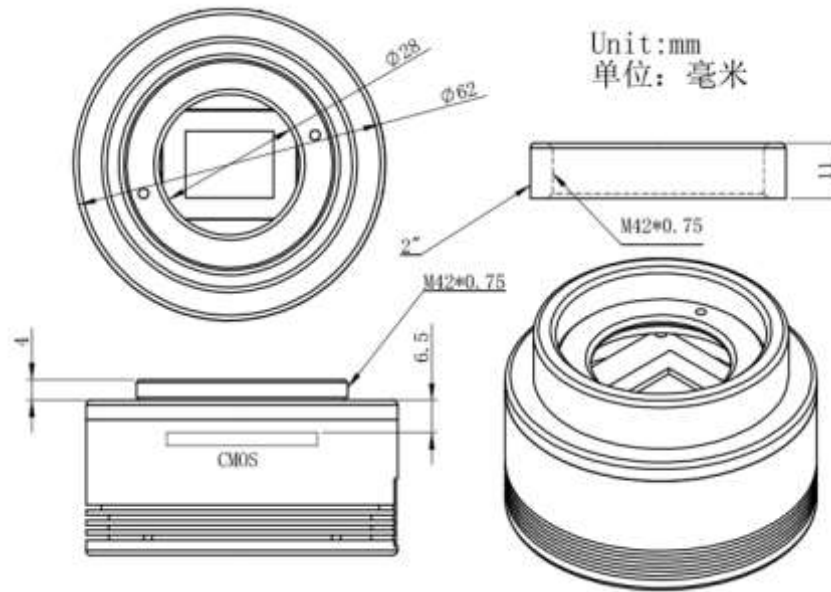

10. Servicing

For software upgrades please refer to “Support-manual and software” on our official website.

<https://astronomy-imaging-camera.com/>

For repairs and consultation: <https://support.astronomy-imaging-camera.com/>

For customers who bought the camera from your local dealer, dealer is responsible for the customer service.

11. Warranty

We provide 2-year warranty for our products, we will offer repair service for free or replace for free if the camera doesn't work within warranty period.

After the warranty period, we will continue to provide repair support and service on a charged basis.

This warranty does not apply to damage that occurred as a result of abuse or misuse, or caused by a fall or any other transportation failures after purchase.

Customer must pay for shipping when shipping the camera back for repair or replacement.