

ZWO DSO Camera ASI2600MC/MM Pro Product Manual



Thank you for purchasing the ZWO ASI camera! Please read this manual carefully before using this product. The copyright and modification rights of this manual and other related materials belong to Suzhou ZWO Co., Ltd.

Table of contents

1. Product Introduction	3
Amazing Craftsmanship, Lightweight Body, Solid Image Quality	3
APS-C Format.....	3
Native 16bit ADC.....	4
IMX571 Backlit Sensor.....	4
Zero Amp Glow	5
2. Notice for Use.....	6
3. Getting to Know Your Camera.....	7
3.1 External View.....	7
3.2 Camera Specifications.....	8
3.3 Quantum Efficiency & Read Noise.....	8
3.4 Analog to Digital Converter (ADC)	10
3.5 Two-Stage TEC Cooling	11
3.6 Anti-Dew	11
3.7 Power Consumption	12
3.8 DDR Buffer	12
3.9 Sensor Tilt Adjustment.....	13
4. What's in the Box?.....	14
5. Structural Dimension Diagram.....	15
6. Connection Methods.....	16
6.1 Connecting to Nikon/Canon Lens.....	16
6.2 Solutions for 55mm best back focus distance	17
6.3 Connecting to external devices.....	19
7. Warranty.....	20
8. Servicing	21

1. Product Introduction



Note: OSC version photo for demonstration here. There are no big differences between the appearance of the OSC version and the mono version except for the camera name on the base. If no additional explanation is added below, photos of the OSC version will be prioritized.

ASI2600MC/MM Pro uses Sony’s latest back-illuminated IMX571 APS-C format sensor with a native 16-bit ADC. It has a small pixel size of 3.76μm, ultra-low 1.0e readout noise, ultra-high 14 stops dynamic range and an innovative breakthrough resulting in zero amp-glow. It has an impressive range of features that make it a popular choice for astrophotographer.

Amazing Craftsmanship, Lightweight Body, Solid Image Quality

ZWO has been working hard to reduce the weight of the camera while still improving the performance of the camera. After years of technical accumulation and repeated weight loss experiments by ZWO engineers, ZWO finally concentrated the ASI2600 to 0.7KG.



APS-C Format

The ASI2600 Pro camera uses an APS-C format sensor, with a length and width of 23.5mm*15.7mm and a diagonal of 28.3mm. It features the resolution of 6248*4176 (26MP in total), and a pixel size of 3.76um, which can accommodate a well depth of 50ke.

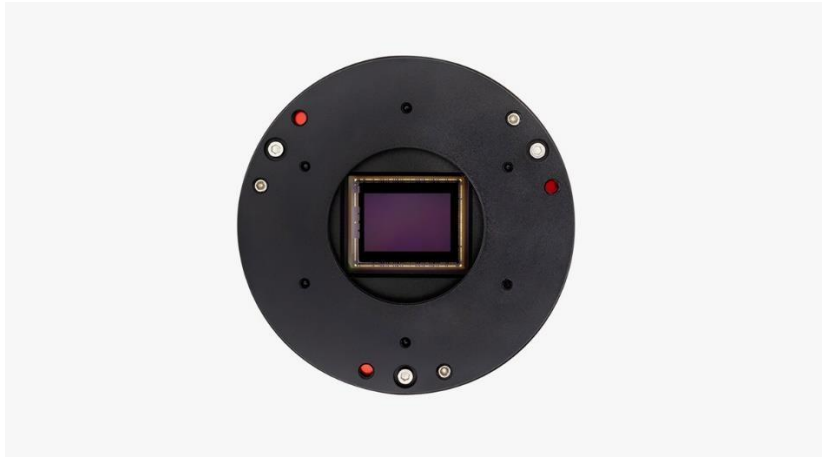

Native 16bit ADC

As one of the few CMOS astronomy cameras with 16-bit ADC on the market, ASI2600 Pro camera was conceived having in mind the optimal characteristics for astrophotography. This 16bit ADC is not a CCD 16bit ADC. It can really achieve a dynamic range output of 14 stop, which will significantly improve the image sharpness and contrast, and also create smoother and more natural contrast transitions (as well as color gradients when using different types of filters).



IMX571 Backlit Sensor

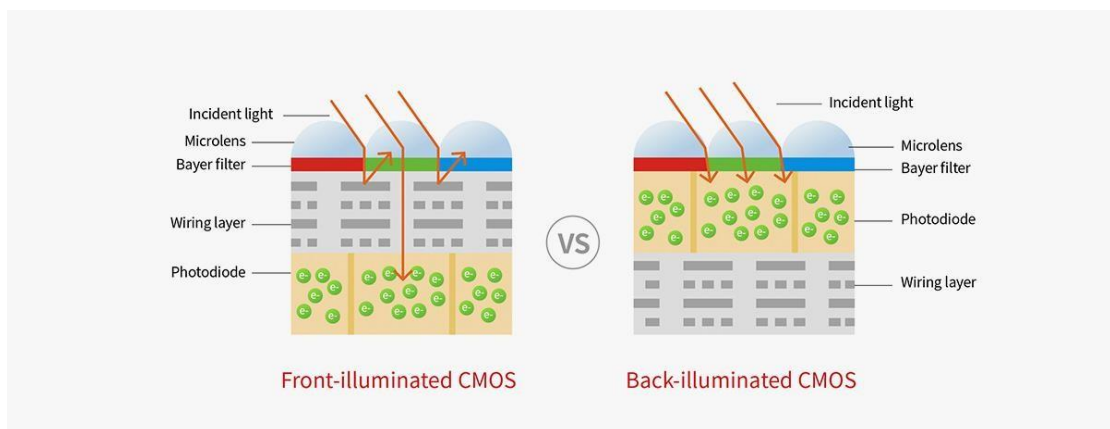

Sony's back-illuminated CMOS image sensor improves the sensitivity and noise reduction – the key factors to enhancing image quality. It does this by radically realigning the fundamental pixel

structure from front-illumination to back-illumination, while still retaining the advantages of CMOS image sensors such as low power consumption and high-speed operation.

With a conventional front-illumination structure, the metal wiring and transistors on the surface of the silicon substrate that form the sensor's light-sensitive area (photo-diode), impede photongathering carried out by the on-chip lens. A back-illuminated structure minimizes the degradation of sensitivity to the optical angle response, while also increasing the amount of light that enters each pixel due to the lack of obstacles such as metal wiring and transistors. These components have been moved to the back-side of the silicon substrate.

Zero Amp Glow

Traditional CMOS sensors produce a weak infrared light source during operation quite often seen in the corner of uncalibrated images. It is the tell-tale signs of 'amp glow'. As the ASI2600 Pro uses zero amp glow circuitry, you won't have to worry about amp glow even when using high gain, long exposure imaging.

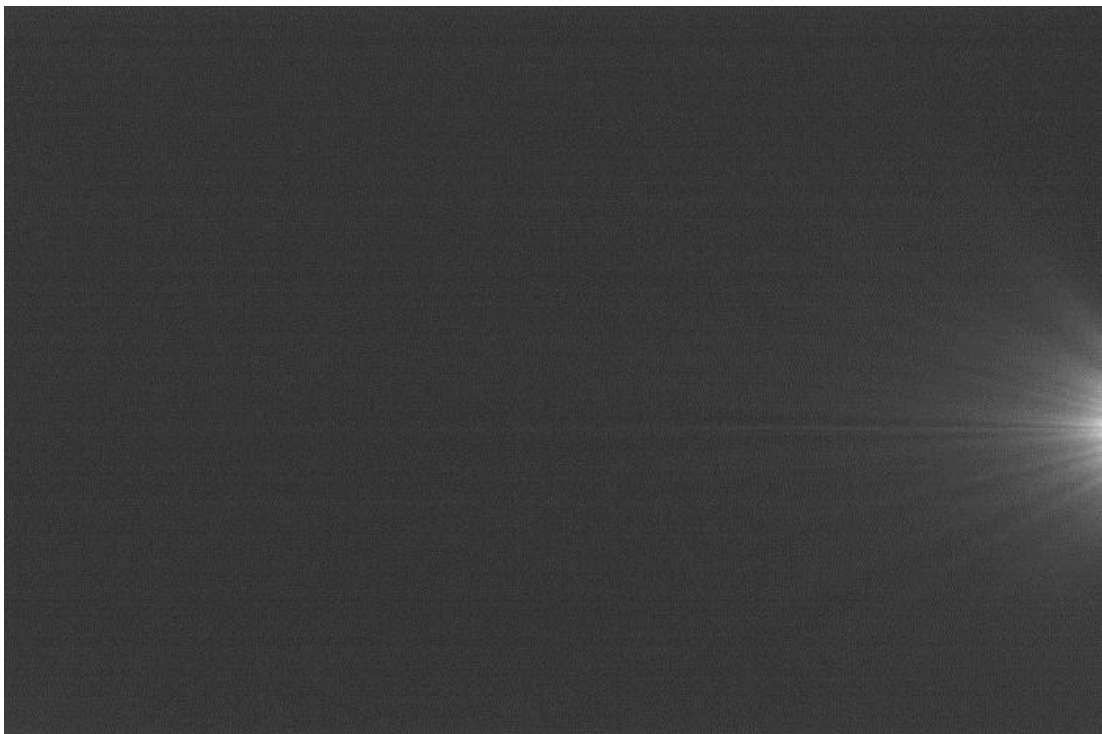

(Dark flame with amp glow – 300s exposure time)



(Dark frame from ASI2600 without any amp glow – 300s exposure time)

2. Notice for Use

Before using the camera, please read this notice carefully.

External power supplies are needed for all ASI cooled cameras. We recommend you use a 12V@3A~5A DC adapter (D5.5x2.1mm, center pole positive) or a lithium battery with 11-14V to power the camera. You can also use ASIAIR to power the camera. Be aware that using power supply out of this voltage range will probably lead to irreparable damage to the camera.

Note that the camera can only be used and stored under the following conditions. Usage outside of the environment limits might lead to damage to the camera.

Storage temperature	-20°C ~ 60°C
Storage humidity	20% ~ 95%
Working temperature	-5°C ~ 50°C
Working humidity	20% ~ 80%

Please do not use corrosive solutions to clean the camera to avoid corroding the oxide layer on the surface and damaging the camera. Meanwhile, please do not keep the camera exposed to the sun for a long time to avoid discoloration of the oxide layer on the camera surface.

3. Getting to Know Your Camera

3.1 External View



1. Protective window: D60*2mm. AR coating for monochrome camera, IR-Cut coating for OSC camera.
2. Sensor tilt plate: M42*0.75, thickness 5mm. It can be screwed off if needed.
3. Heat sink
4. USB 2.0 Hub
5. USB 3.0/USB 2.0 data transmission port
6. DC power port: D5.5x2.1mm, center pole positive. It is recommended to use a 12V@3A power supply.
7. Ultra-quiet magnetic levitation fan: Only runs when cooling is turned on.

The camera can be supported by the ZWO holder ring. There is a 1/4" screw port at the base of the ring.



3.2 Camera Specifications

Sensor	SONY IMX571BLR-J CMOS (Mono) SONY IMX571BQR-C CMOS (OSC)
Sensor format	APS-C
Diagonal	28.3mm
Resolution	26MP (6248*4176)
Pixel size	3.76μm
Sensor size	23.5mm*15.7mm
Max frame rate	3.51FPS
Shutter	Rolling shutter
Exp range	32μs-2000s
Read noise	1.0-3.3e
QE peak	Over 80% (OSC) 91% (Mono)
Full well capacity	50Ke
ADC	16bit
DDR3 buffer	512MB*
USB port	M42*0.75 USB 3.0/USB 2.0
Protective window	AR (OSC) IR-Cut (Mono)
Camera diameter	90mm
Net weight	0.7kg
Back focus distance	17.5mm
Cooling	2-stage TEC cooling
Delta-T	30°C~35°C
Power consumption (Cooling on)	12V, Max current 3A
Supported OS	Windows, Linux & Mac OSX

3.3 Quantum Efficiency & Read Noise

Quantum Efficiency (QE)

According to our test results, the QE peak value of ASI2600MC Pro is above 80%. For ASI2600MM Pro, the QE peak value is 91%.

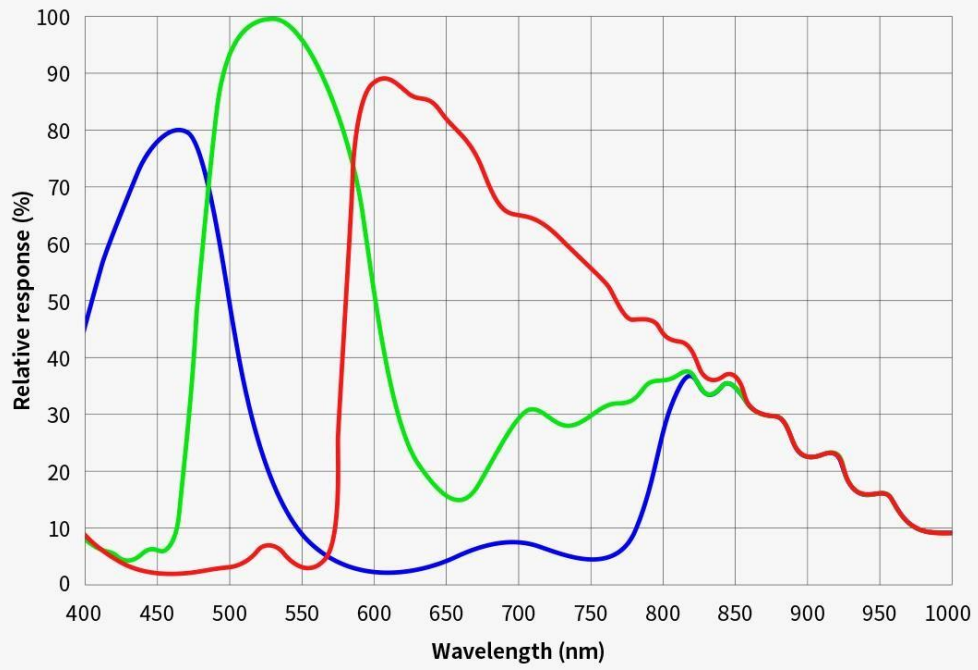

ASI2600MC Pro

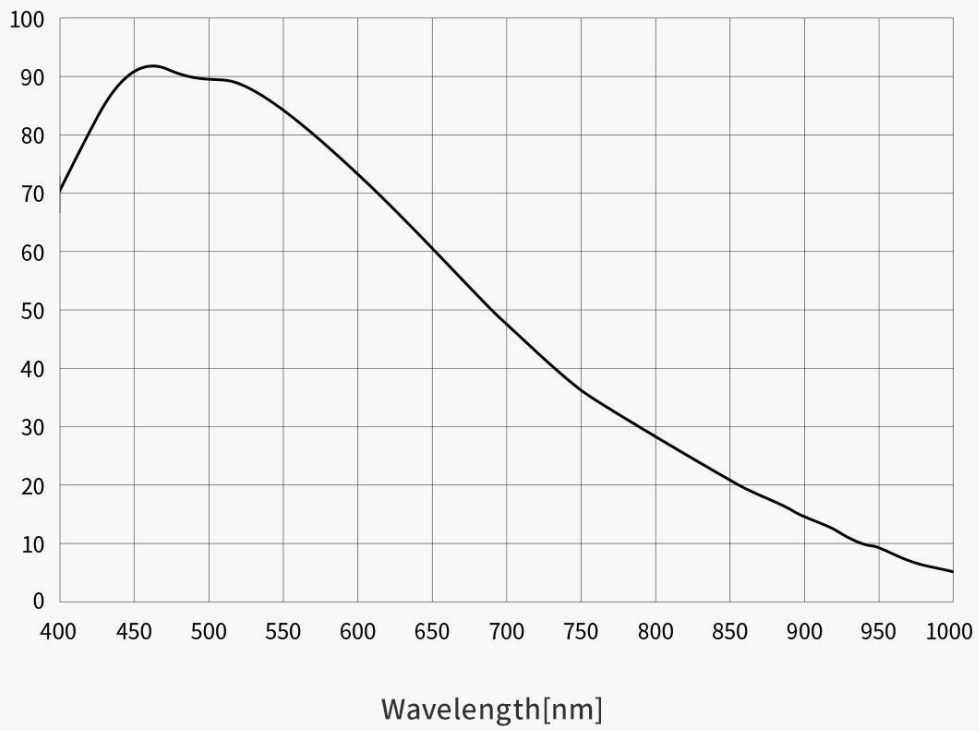

ASI2600MM Pro

Read Noise

ASI2600 has excellent performance with a dynamic range of up to 14 stops that will greatly reduce the issue of overexposed images, and make color gradients look smoother and more natural-looking. When the gain value is set to 100, the HCG high gain mode is turned on. The readout noise is greatly reduced, and the dynamic range is basically unchanged. We recommend you set gain at 0 or 100 for deep sky object imaging.

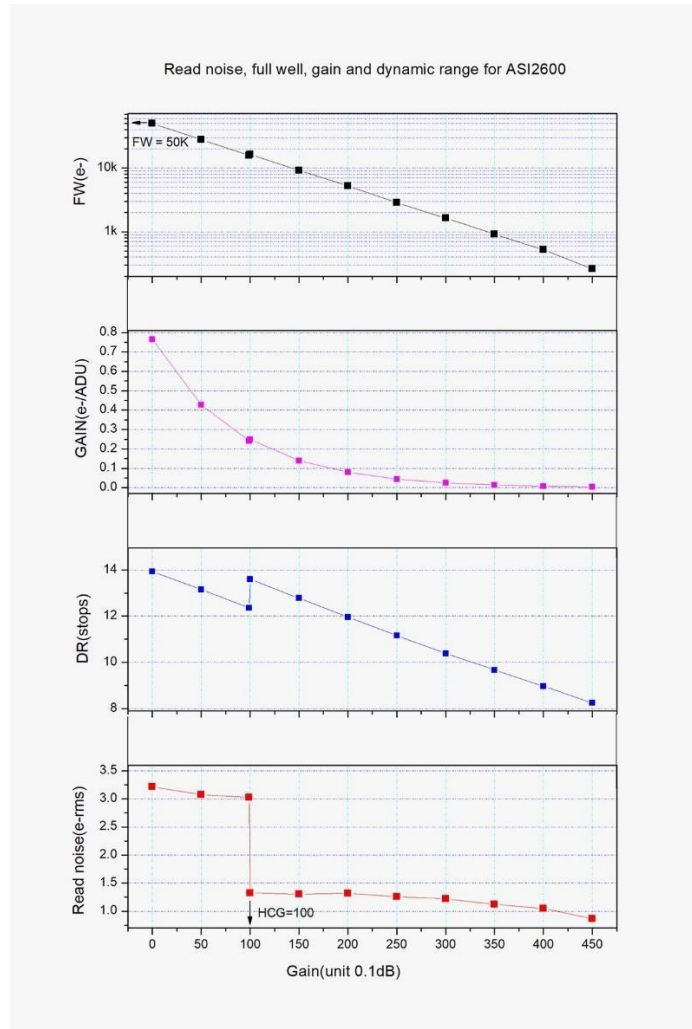

3.4 Analog to Digital Converter (ADC)

ASI2600 has a built-in 16-bit ADC. 12-bit ADC mode for output will be used when we do hardware Bin. It also supports the custom ROI partial readout mode, resulting in a faster frame rate at the smaller ROI resolutions.

Below are the maximum speeds of ASI2600 running at different USB transmission modes in 16bit mode:

Resolution	16Bit ADC	
	USB 2.0	USB 3.0

6248*4176	0.83fps	3.51fps
4096*3072	1.72fps	4.75fps
3840*2160	2.61fps	6.71fps
1920*1080	10.43fps	13.13fps
1280*720	19.29fps	19.29fps
640*480	28.06fps	28.06fps
320*240	51.44fps	51.44fps

3.5 Two-Stage TEC Cooling

Two-Stage TEC Cooling, Ultra-Low Dark Current

Thanks to the two stage TEC cooling, ASI2600 can lower the CMOS sensor temperature to more than 35 degrees Celsius below ambient temperature, which can greatly reduce dark current generation and sensor noise even during extended exposure times.

*The Delta T 35°C is tested at 30°C ambient temperature. It might get down when the cooling system is working for a long time. Also, as the ambient temperature falls, the Delta T would also decrease.

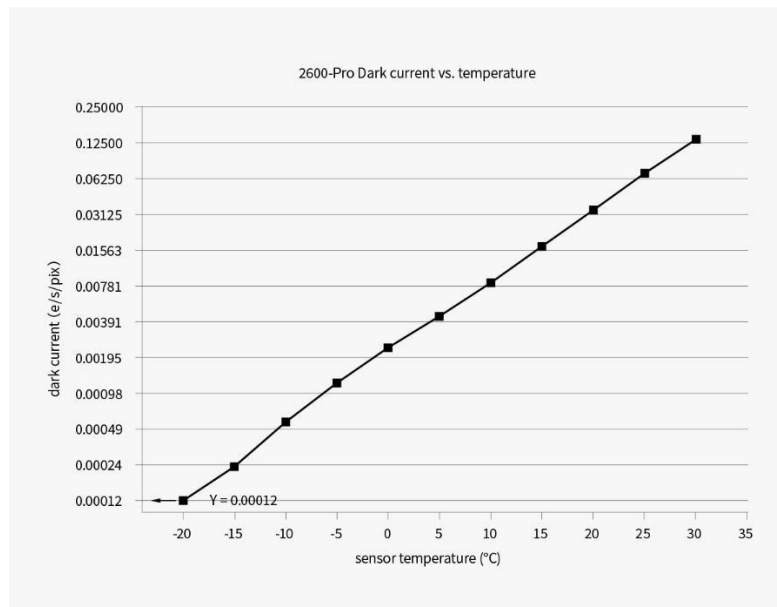

3.6 Anti-Dew

ASI2600 Pro comes with the polyimide heater that completely fits the protective window to avoid dew problems. Its power consumption is around 5W. You can turn this feature off in software if you want to save some power.



3.7 Power Consumption

All ASI cameras have low power consumption. ASI2600 is no exception. When it is not cooling, the max power consumption is only 4.7W. Below is the camera cooling efficiency diagram.

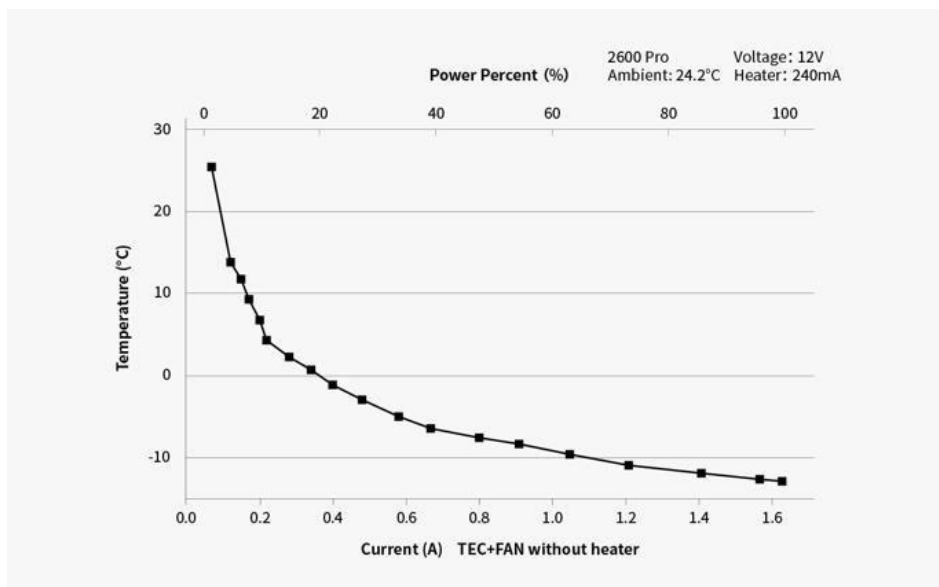

3.8 DDR Buffer

The ASI2600 Pro is equipped with a USB 3.0 transmission interface and a built-in DDR3 cache to ensure stable and secure data transmission.

ASI Cooled Cameras produced after August 2023 have changed their DDR3 buffer from 256MB to 512MB.

3.9 Sensor Tilt Adjustment

There are three sets of screws that can be used to adjust the sensor tilt. Two screws per set for screw in/out.



Here is the guide:

1. Use the camera to take an image with clear stars, and then find out the tilt part in the image with the help of imaging software. Adjust the one or more sets of screws in the corresponding position on the camera.
2. Take another image after the adjustment, compare the new image with the previous one in the software. If the tilt issue is eased, the adjustment direction is correct. If the issue has worsened, the adjustment direction is incorrect.
3. Repeat step 2 until the stars in all corners of the image appear perfect.

4. What's in the Box?



The 2m USB 3.0 cable and two 0.5m USB 2.0 cables can meet multiple requirements in different usage scenarios. For example, the 2m long cable can be used for guiding with a PC. The 0.5m short cables can be used to connect ASIAIR to the guide camera or EAF.

5. Structural Dimension Diagram

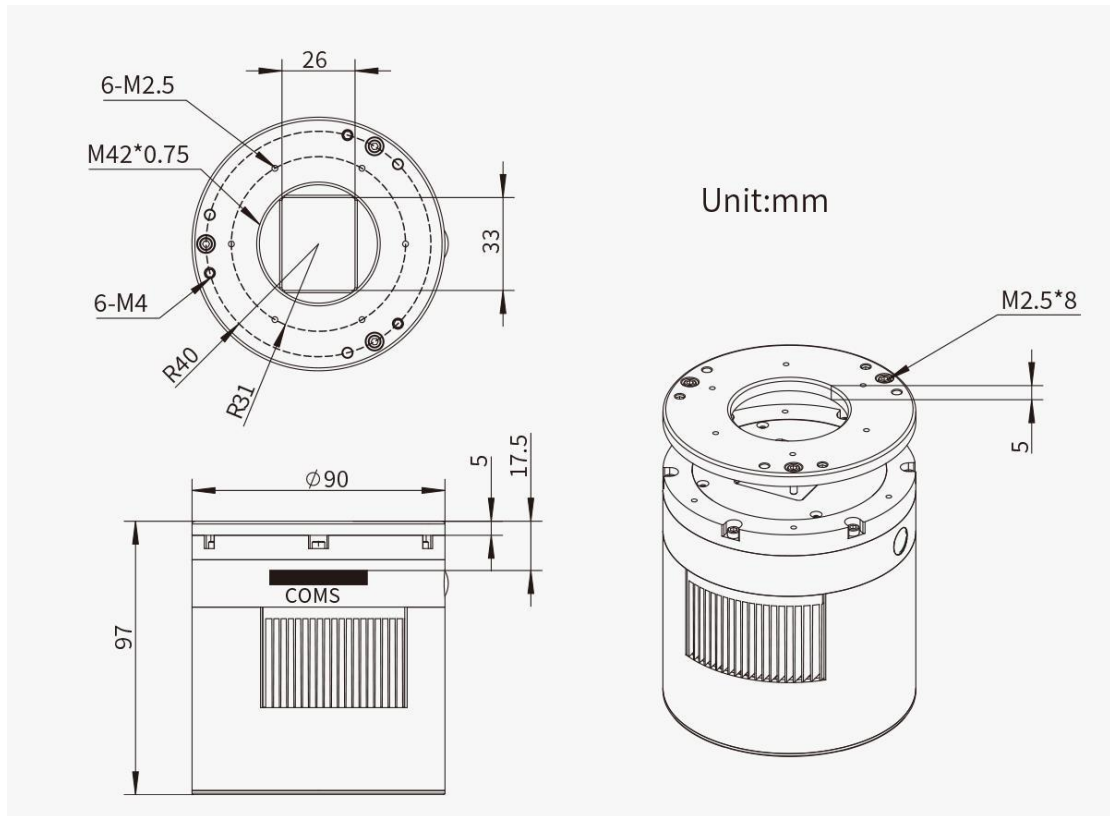

6. Connection Methods

6.1 Connecting to Nikon/Canon Lens

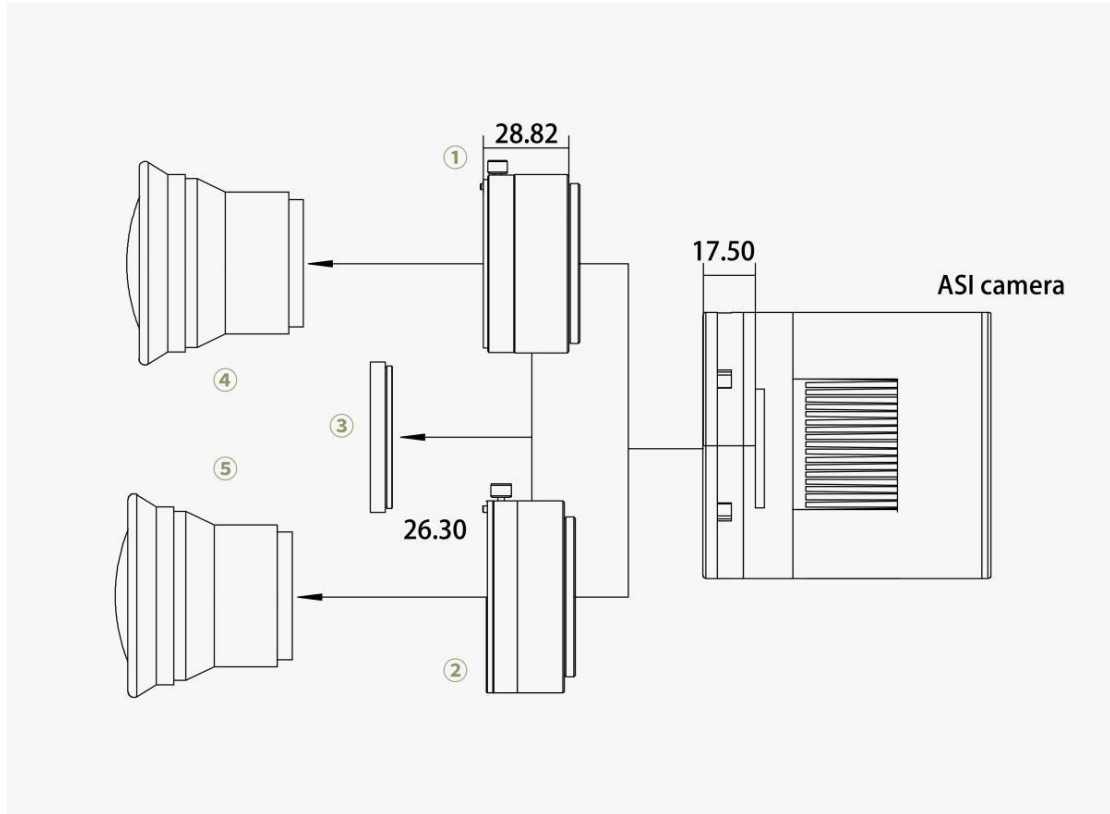

1. Nikon-T2 adapter
2. EOS-T2 adapter
3. 2" filter (optional)
4. Nikon lens
5. Canon lens

6.2 Solutions for 55mm best back focus distance

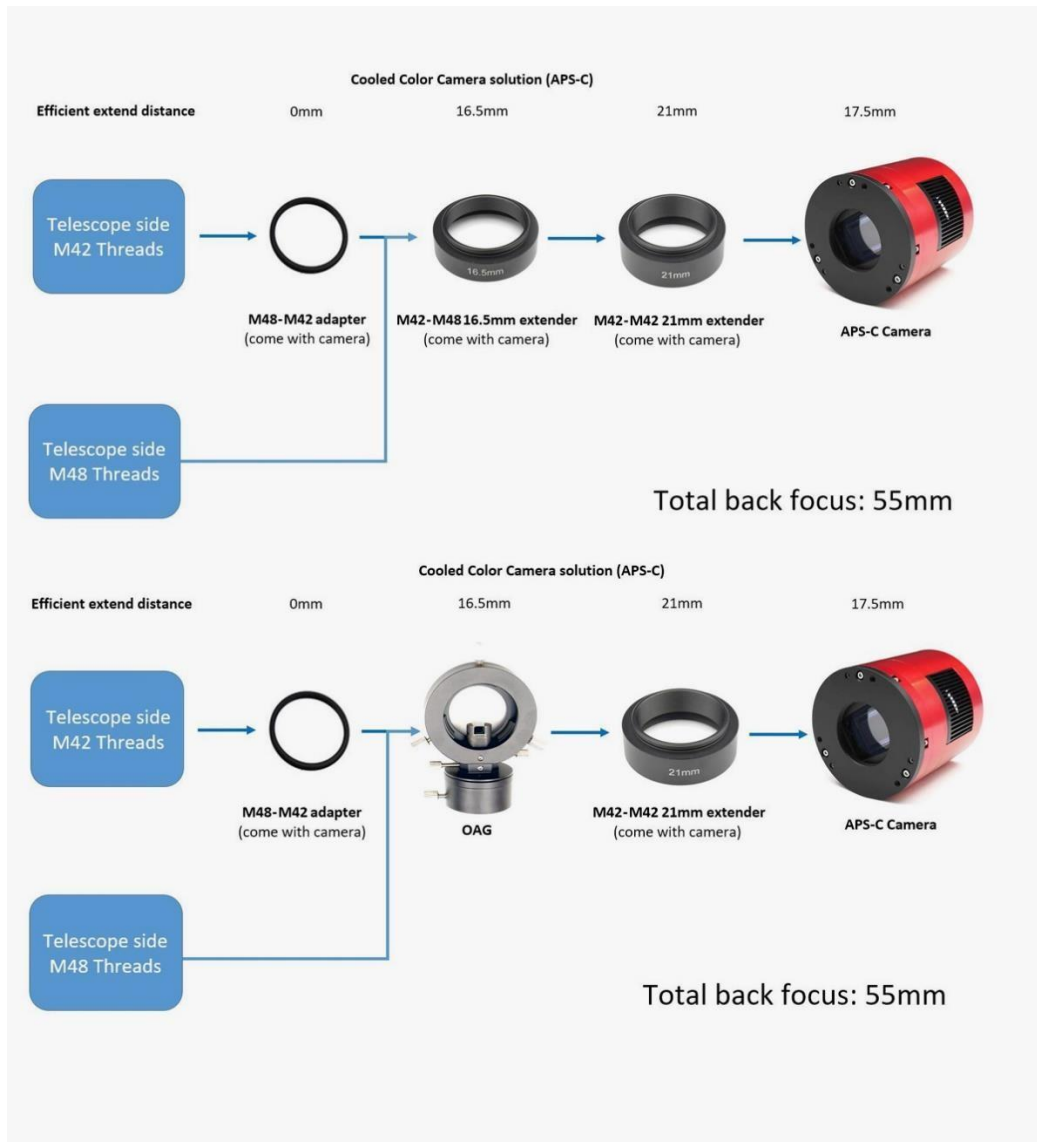

APS-C frame cooled camera connection solutions



APS-C frame cooled camera + M42 filter drawer + OAG



APS-C frame cooled camera + 36mm EFW + OAG



APS-C frame cooled camera + 2" EFW + OAG



For the detailed connection methods of ASI2600 Pro:

<https://www.zwoastro.com/2018/06/14/best-back-focus-length-solutions-55mm/>

6.3 Connecting to external devices

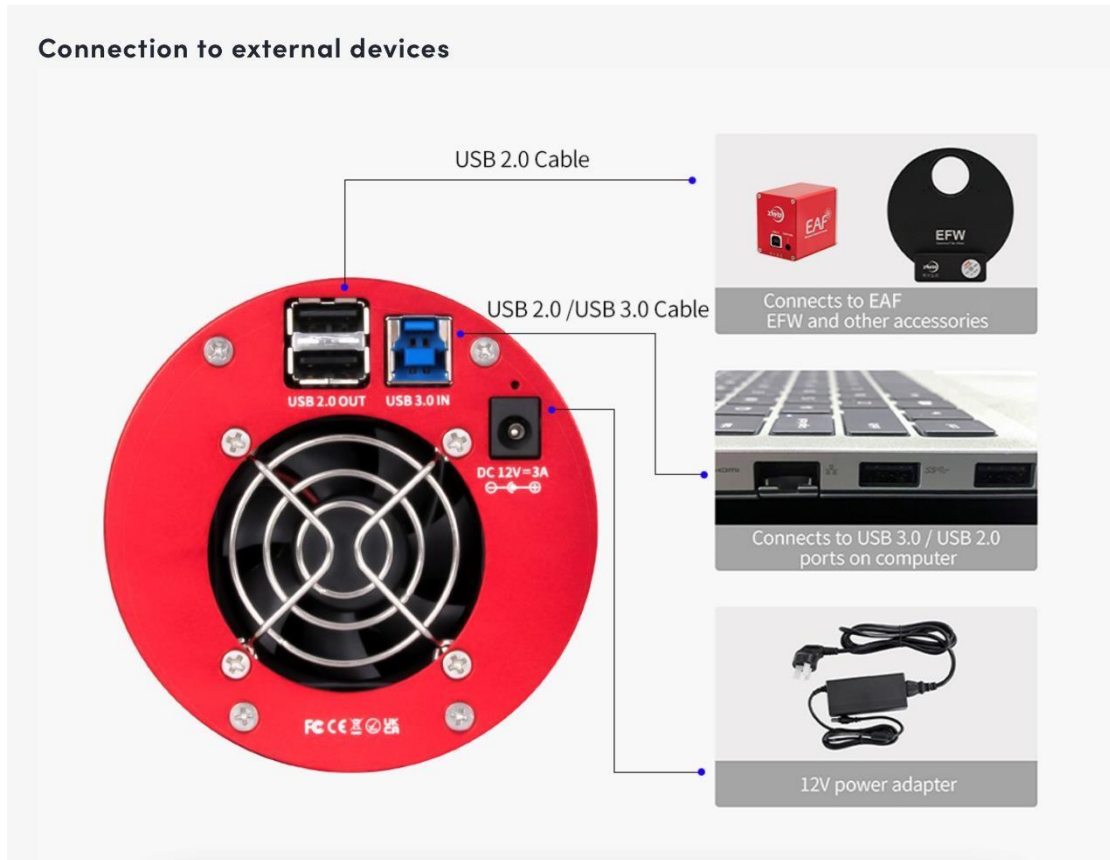

7. Warranty

1. ZWO provides Users with a warranty period of 2 years for ZWO branded products. The warranty starts from the second day when the customer gets the product.
2. If a User encounters the following Dead on Arrival (DOA) and contacts ZWO within the corresponding time limit to issue the Product purchase invoice and relevant evidence, ZWO will provide door-to-door pick-up service and, as appropriate, after-sale replacement (or partial replacement), repair or return (or partial return) service for the following Products:
 - 1) Product quality problem: Provided that a User detects a quality problem and contacts ZWO within 30 days after receipt of the Products, and ZWO support team confirms that the Products indeed have a quality problem or defect after their inspection, ZWO will provide free replacement service towards such Products;
 - 2) Product transportation problem
Provided that a User finds obvious signs of bubbling, serious overstocking, or deformation on the outer package of the Products upon receipt of the Products, and provides ZWO with pictures of the outer package and proof of receipt within 3 days after receipt of such Products, ZWO support team will verify the actual shipper and determine the responsible party for such transportation problem. In the event that ZWO is the actual shipper, ZWO will be responsible for providing the relevant return or replacement service, however, if the Products are directly sold or transported to the User by an agent of ZWO, the agent will be responsible for providing the relevant return or replacement service.
 - 3) Quality problems with product accessories or other parts are not a condition for returning the product. Users can request to replace new accessories separately.
3. If the Products are under the following circumstances, they are not within the scope of warranty service, ZWO may provide maintenance services to the Users:
 - 1) The Warranty Period of the Products has expired; or
 - 2) The Products are injected into liquid or affected by moisture or corrosion; or
 - 3) The Products are damaged by an external force (such as the broken of the camera protection window glass, the deformation of the product shell, the broken of the USB port, etc.); or
 - 4) Disassembling, repairing by a third party, refurbishment of the Products (such as downloading erroneous firmware) without the written authorization of ZWO; or
 - 5) The product system is modified, or the maintenance notice is lost or changed; or
 - 6) Product quality problem caused by installation not following the requirements or instructions for the Products; or
 - 7) Physical damage or failure of the Products caused by the force majeure (such as solid vibration or extrusion such as flood, fire, earthquake, or thunder stroke); or
 - 8) Damage caused by the improper User operation during the period of shooting or use, such as using without the equipment protection or direct shooting of the sun; or
 - 9) No valid purchase invoice or warranty certificate; or
 - 10) The Products are second-hand products.

8. Servicing

For software upgrades, please refer to “Guide & Manuals” on our official website.

<https://www.zwoastro.com/guides-and-manuals/>

For repairs and consultation, you can visit here: <https://support.astronomy-imaging-camera.com/>

Email: info@zwoptical.com

Phone: 0512-65923102

1. For the normal repair or replacement of the Products during the Warranty Period, the User will bear the return cost. When returning the Products, Users shall specify the actual reasons for the damage to the Products, and shall provide the corresponding valid certificates, such as pictures or videos, etc.

For the Products that need to be replaced after being confirmed by ZWO in writing, the User shall return the Products with the complete package, together with all accessories, manuals, etc., to the address designated by ZWO.

By sending back the product to ZWO, the User agrees to pay out-of-warranty fees that may arise during the repair process of the product. ZWO will send back the product after charging.

2. For the Products that need to be returned for after-sales service, ZWO will provide the corresponding RMA code for reference. ZWO will not accept any products having no RMA code that have been returned privately without ZWO written confirmation.

3. If a User purchases the ZWO Products from a ZWO agent, the User may contact the ZWO agent directly for the relevant after-sales service.