

Planetary Camera ASI715MC

Product Manual



Thank you so much for purchasing ZWO ASI camera! Before using the product, please read this manual carefully.
All materials related to this publication are subject to change without notice and its copyright totally belongs to Suzhou ZWO CO.,LTD.

Contents

1 Product Introduction	1
2 Notice for Use	3
3 Getting to Know Your Camera	4
3.1 External View	4
3.2 Camera Specifications	5
3.3 Quantum Efficiency & Read Noise	6
3.4 Analog to Digital Converter (ADC)	8
3.5 Power consumption	8
4 What's in the Box?	9
5 Structural Dimension Diagram	9
6 Connection Methods	10
7 Warranty	11
8 Servicing	12

1 Product Introduction



Color Camera with Small Pixels

ASI715MC is a sensitive color camera with a 1/2.8" sensor and 8.46MP resolution. With the Sony STARVIS technology, this camera has very low read noise (0.72e) and ultra-high sensitivity, making it ideal for astronomical imaging of the planets and smaller deep-sky objects and also for microscope photography

Also, thanks to the 1.45μm small pixel size and 4k resolution, this camera offers very sharp object details in use even without a Barlow lens.

STARVIS

ASI715MC adopts SONY STARVIS CMOS sensor. It has an amazing feature of zero amp glow, and also a great sensitivity in NIR wavelength.

STARVIS

High Speed Transmission

ASI715MC is equipped with a USB 3.0 transmission port and a built-in 256MB DDR cache to ensure stable and secure data transmission.



USB 3.0 Port & ST4 Guide

USB 3.0 Port: Provides 5Gbps bandwidth to allow ASI715MC to run at 45.1fps (10bit, high speed mode).

ST4 Port: Can be used to connect with the auto guide port of mount for guiding.



2 Notice for Use

Before using the camera, please read this manual carefully.

Note that the camera can only be used and stored under the following conditions. Usages out of the environment limits might lead to damage to the camera.

Storage temperature	-20°C ~ 60°C
Storage humidity	20% ~ 95%
Working temperature	-5°C ~ 50°C
Working humidity	20% ~ 80%

Please do not use corrosive solutions to clean the camera to avoid corroding the oxide layer on the surface and damaging the camera. Meanwhile, please do not keep the camera exposed to the sun for a long time to avoid discoloration of the oxide layer on the camera surface.

3 Getting to Know Your Camera

3.1 External View



- ① USB 3.0/2.0 port
- ② ST4 guide port
- ③ AR protective window (D21x1.1mm)
- ④ 1/4" screw for fixing the camera to the tripod

3.2 Camera Specifications

Sensor	Sony-IMX715
Sensor format	Type 1/2.8
Diagonal	6.43mm
Resolution	8.46MP (3864x2192)
Pixel size	1.45 μ m
Sensor size	5.602mmx3.178mm
Fast frame rate	45.1fps
Shutter	Rolling shutter
Exposure range	32 μ s~2000s
Read noise	0.72-2.1e(1.8e@3.5db gain)
QE peak	80%
Full well capacity	6.03Ke
ADC	12bit
USB interface	USB 3.0 / USB 2.0 Type-B
Adapters	1.25"/2"/M42x0.75
Protect window	ϕ 21-1.1 AR
Dimension	62mm
Weight	126g
Back focus distance	12.5mm
Supported OS	WIN7/8/10 32&64、Linux、 Mac

3.3 Quantum Efficiency & Read Noise

Quantum Efficiency

QE curve and read noise are very important parameters to measure the camera's performance. Higher QE and lower read noise are necessary to improve the image signal-to-noise ratio.

According to our estimation, the QE peak value of ASI715MC is about 80%.

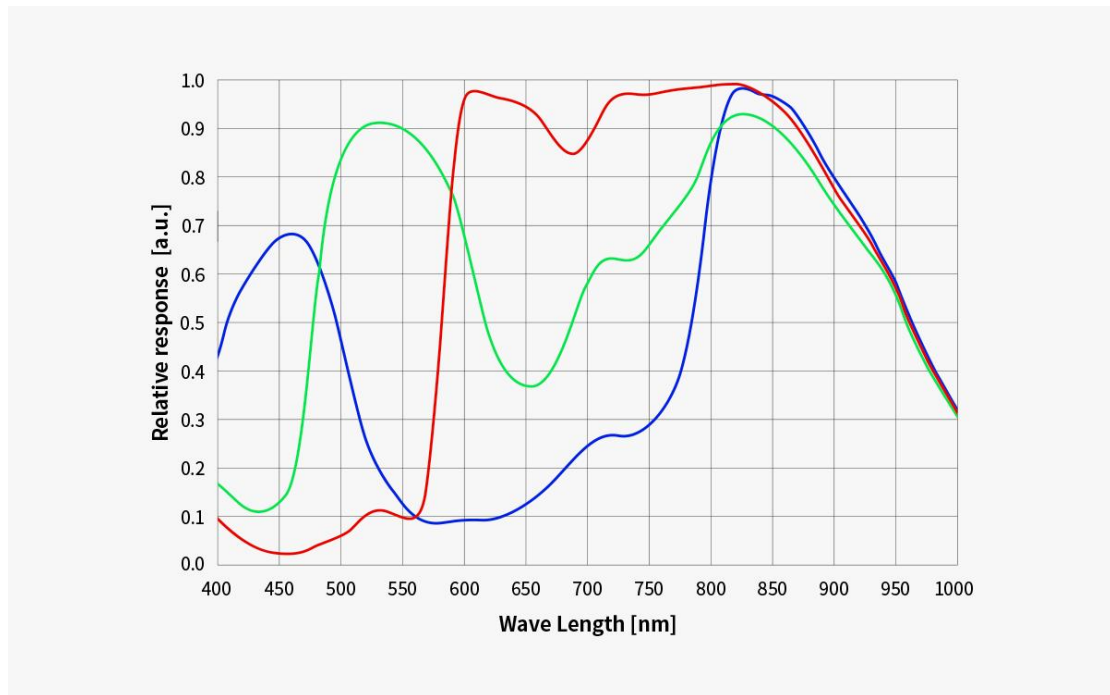

Read Noise

Read noise contains pixel noise, circuit noise and ADC noise. The lower the read noise is, the better.

ASI715MC's read noise is very low. And with the gain value going high, the read noise goes lower and lower.

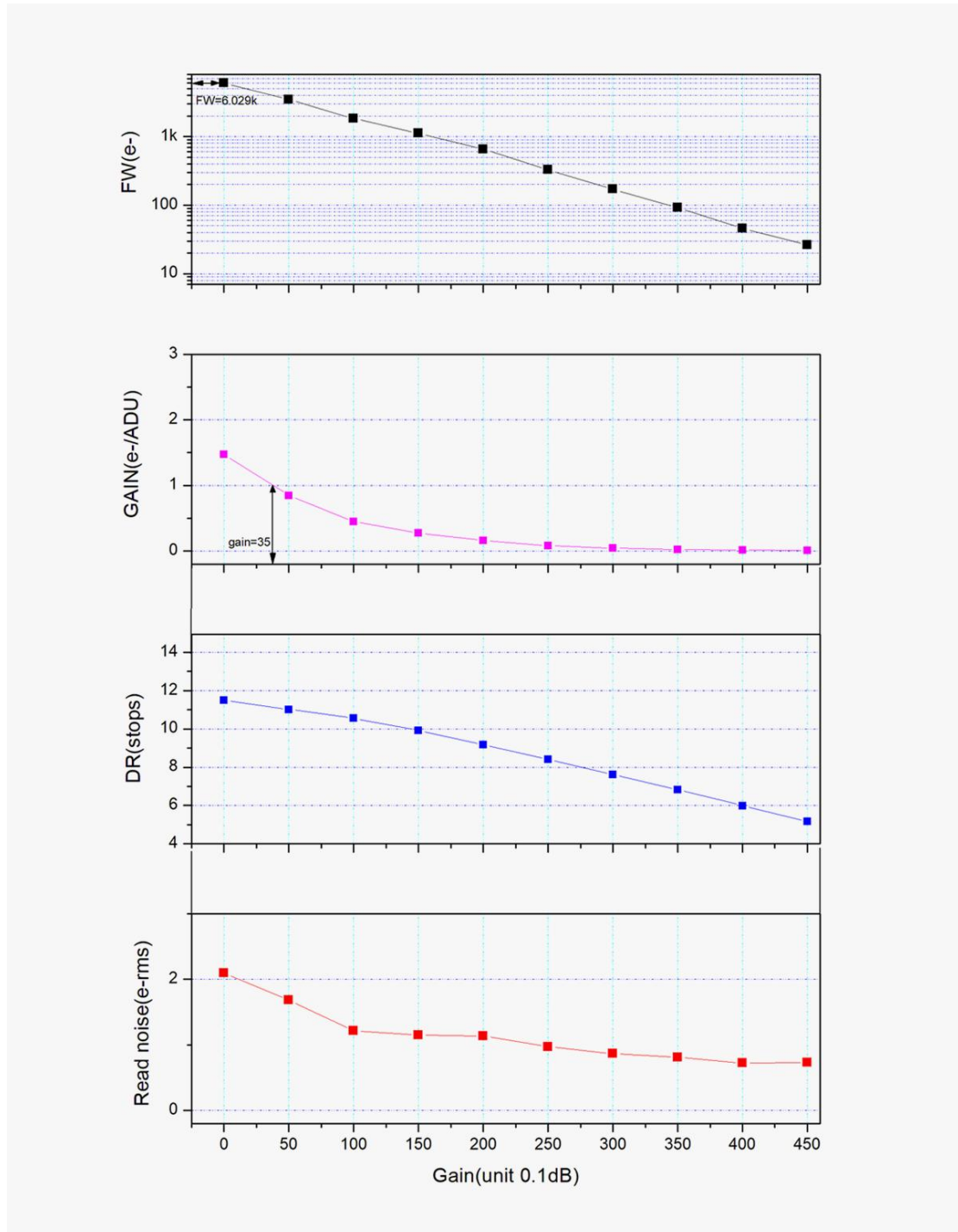

3.4 Analog to Digital Converter (ADC)

ASI715 records in 12bit ADC and 10bit ADC. You can image at a faster frame rate if you use 10bit ADC (high speed mode). You may also set an ROI if you want even faster frame rates. Below are the maximum speeds of ASI715 running at different USB transmission modes.

Resolution	USB 3.0			USB 2.0		
	12BIT ADC		10BIT ADC	12BIT ADC		10BIT ADC
	RAW16	RAW8	RAW8	RAW16	RAW8	RAW8
3864*2192	23.3fps	38.0fps	45.1fps	2.05fps	4.1fps	4.1fps
1920*1080	75.1fps	75.1fps	89.1fps	8.4fps	16.7fps	16.7fps
1280*720	109.7fps	109.7fps	130.2fps	18.8fps	37.6fps	37.6fps
640*480	158.3fps	158.3fps	188.1fps	56.4fps	113fps	113fps
320*240	285.1fps	285.1fps	338.7fps	226.6fps	285.1fps	338.6fps

3.5 Power consumption

All ASI cameras have low power consumption. ASI715 is no exception. When it is powered with a USB cable, the max power consumption is only 1.36W.

4 What's in the Box?

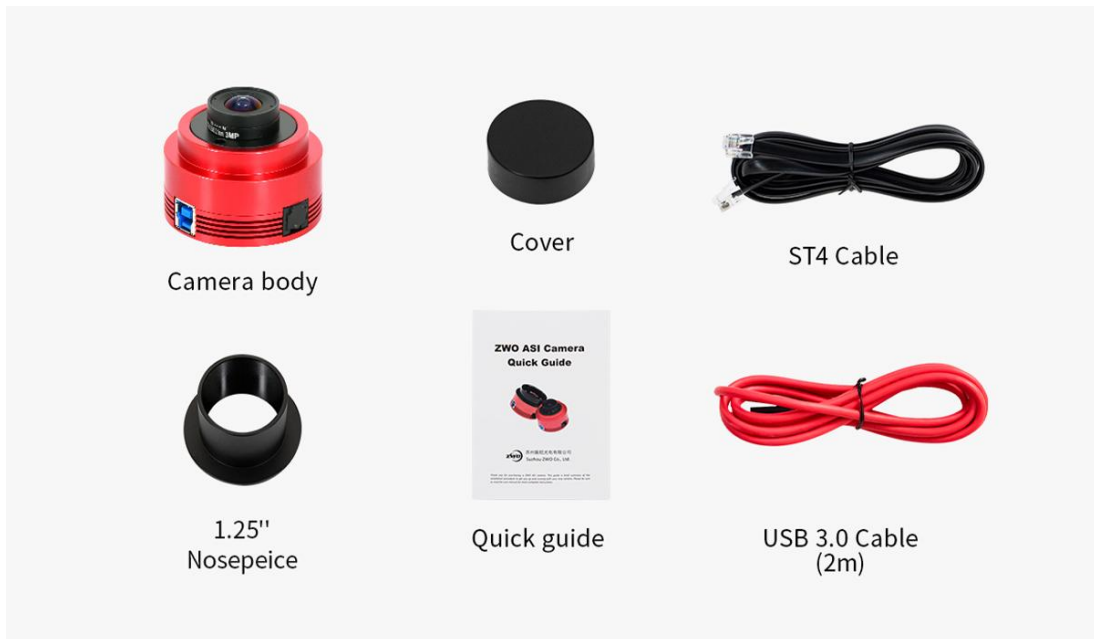

Equipped with a 2m USB cable that can be used to connect the computer and the camera for guiding.

Note: Please take off the self-contained lens on the top of the camera if you want to use the camera for astrophotography.

5 Structural Dimension Diagram

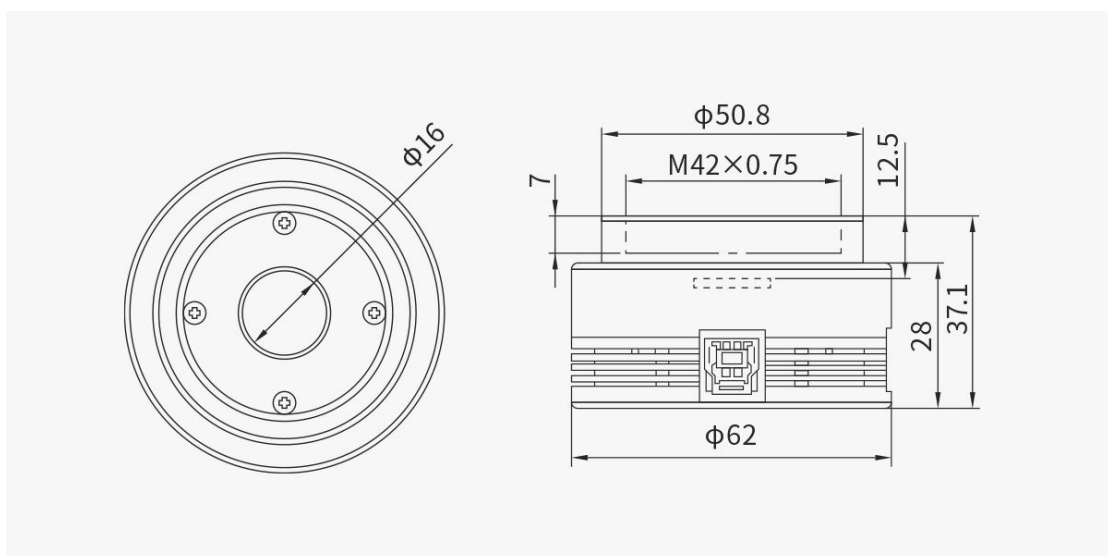

6 Connection Methods

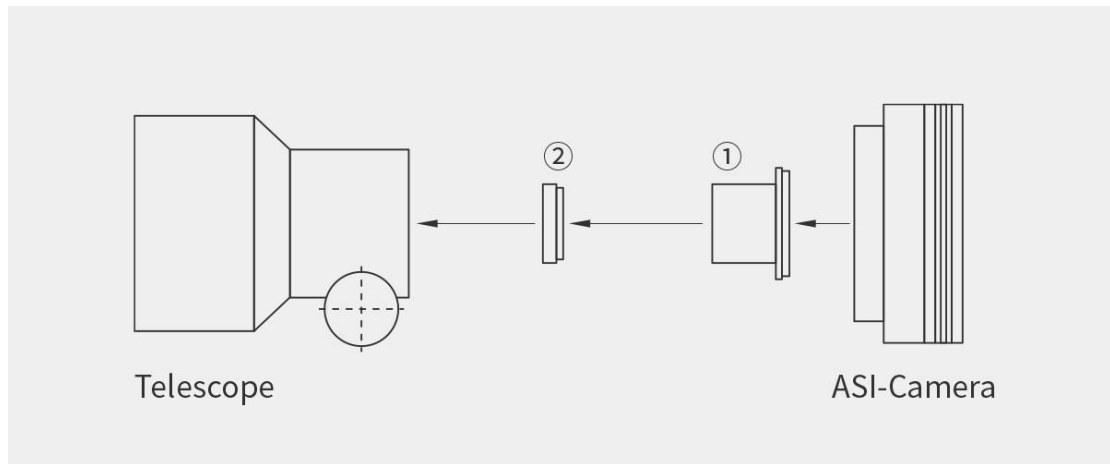

① 1.25" T-mount

② 1.25" filter (optional)

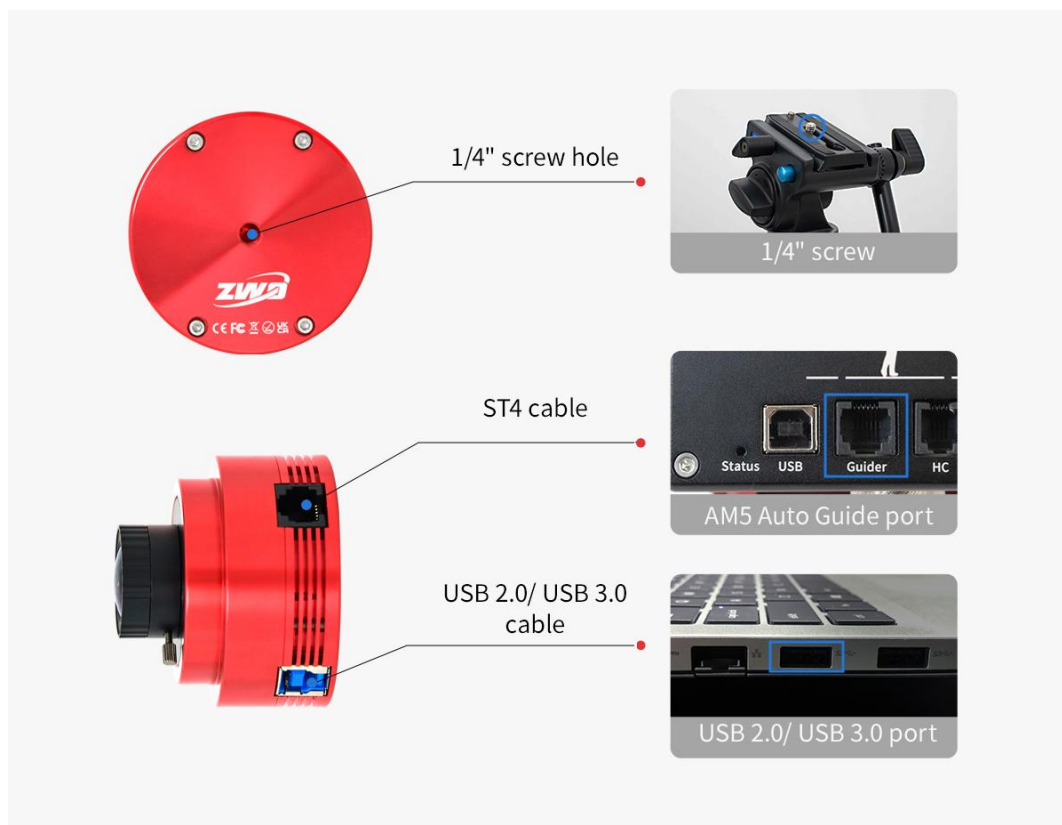

7 Warranty

1. ZWO will provide a 2-year free warranty service (Warranty Period) for ZWO products purchased by Users from ZWO ("Products") in accordance with this Policy, commencing on the day following receipt of the Products by Users. For ASI AIR Plus users, commencing on the day of device activation.

2. If a User encounters the following Dead on Arrival (DOA) and contacts ZWO within the corresponding time limit to issue the Product purchase invoice and relevant evidence, ZWO will provide door-to-door pick-up service and, as appropriate, after-sale replacement (or partial replacement), repair or return (or partial return) service for the following Products:

1) Product quality problem

Provided that a User detects a quality problem and contacts ZWO within 180 days after receipt of the Products, and ZWO support team confirms that the Products indeed have a quality problem or defect after their inspection, ZWO will provide free replacement service towards such Products;

2) Product transportation problem

Provided that a User finds obvious signs of bubbling, serious overstocking, or deformation on the outer package of the Products upon receipt of the Products, and provides ZWO with pictures of the outer package and proof of receipt within 3 days after receipt of such Products, ZWO support team will verify the actual shipper and determine the responsible party for such transportation problem. In the event that ZWO is the actual shipper, ZWO will be responsible for providing the relevant return or replacement service, however, if the Products are directly sold or transported to the User by an agent of ZWO, the agent will be responsible for providing the relevant return or replacement service.

3) Any quality problem with the accessories or other parts of the Products is not a condition for the return or change of the Products, and the User may solely request to replace the accessories with new ones, which shall be handled after verification by ZWO support team.

3. If the Products are under the following circumstances, they are not within the scope of warranty service. ZWO may provide maintenance services to the Users:

1) The Warranty Period of the Products has expired;

2) The Products are injected into liquid or affected by moisture or corrosion;

3) The Products are damaged by an external force (such as the broken of the camera protection window glass, the deformation of the product shell, the broken of the USB port, etc.);

4) Disassembling, repairing by a third party, refurbishment of the Products (such as downloading erroneous firmware) without the written authorization of ZWO;

5) The product system is modified, or the maintenance notice is lost or changed;

6) Product quality problem caused by installation not following the requirements or instructions for the Products;

7) Physical damage or failure of the Products caused by the force majeure (such as strong vibration or extrusion such as flood, fire, earthquake, or thunder stroke);

8) Damage caused by the improper User operation during the period of shooting or use, such as using without the equipment protection or direct shooting of the sun;

9) No valid purchase invoice or warranty certificate;

10) The Products are second-hand products.

8 Servicing

For software upgrades, please refer to "Guide & Manuals" on our official website.

<https://www.zwoastro.com/guides-and-manuals/>

For repairs and consultation, you can visit here:

<https://support.astronomy-imaging-camera.com/>

Email: info@zwoptical.com.

Phone: 0512-65923102

1. For the normal repair or replacement of the Products during the Warranty Period, the User will bear the return cost. When returning the Products, Users shall specify the actual reasons for the damage to the Products, and shall provide the corresponding valid certificates, such as pictures or videos, etc.

For the Products that need to be replaced after being confirmed by ZWO in writing, the User shall return the Products with the complete package, together with all accessories, manuals, etc., to the address designated by ZWO.

By sending back the product to ZWO, the User agrees to pay out-of-warranty fees that may arise during the repair process of the product. ZWO will send back the product after charging.

2. For the Products that need to be returned for after-sales service, ZWO will provide the corresponding RMA code for reference. ZWO will not accept any products having no RMA code that have been returned privately without ZWO written confirmation.

3. If a User purchases the ZWO Products from a ZWO agent, the User may contact the ZWO agent directly for the relevant after-sales service.